



LEDTECH ELECTRONICS CORP.

USA Sales Office
19209 Parthenia Street - Suite D
Northridge, CA 91324
Phone: (818) 701-7240
Fax: (818) 701-7217

SPECIFICATION

PART NO. : UT18W2-4D-URC3-12V
5.0mm ROUND LED LAMP



Approved by	Checked by	Prepared by
<i>Tung</i>	<i>Yang</i>	<i>Haibo</i>

Description

This white lamp is made with InGaN/Sapphire chip and white diffused epoxy resin.

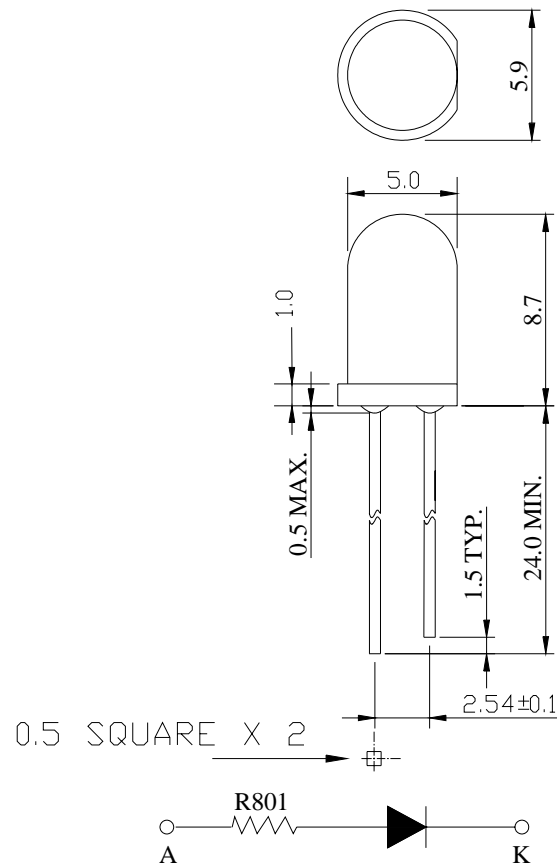

Notes:

1. All dimensions are in mm.
2. Tolerance is ±0.25mm unless otherwise noted.

Description

Part No.	LED Chip		Lens Color
	Material	Emitting Color	
UT18W2-4D-URC3-12V	InGaN/Sapphire	White	White diffused

**UT18W2-4D-URC3-12V****5.0mm ROUND LED
LAMP****Absolute Maximum Ratings at Ta=25**

Parameter	Symbol	Rating	Unit
Power Dissipation	P _D	360	mW
Reverse Voltage	V _R	5	V
D.C. Forward Current	I _f	30	mA
Reverse (Leakage) Current	I _r	50	μA
Peak Current(1/10Duty Cycle,0.1ms Pulse Width.)	I _f (Peak)	100	mA
Operating Temperature Range	T _{opr.}	-25 to +85	
Storage Temperature Range	T _{stg.}	-40 to +100	
Soldering Temperature(1.6mm from body)	T _{sol.}	Dip Soldering : 260°C for 5 sec. Hand Soldering : 350°C for 3 sec.	
Electrostatic discharge	ESD.	300	V

Electrical and Optical Characteristics:

Parameter	Symbol	Condition	Min.	Typ.	Max.	Unit
Luminous Intensity	I _v	V _f =12V	500	1100		mcd
Forward Current	I _f	V _f =12V		10.0	12.0	mA
CIE Chromaticity Coordinates:X Axis	X	V _f =12V		0.31		
CIE Chromaticity Coordinates:Y Axis	Y	V _f =12V		0.30		
Reverse (Leakage) Current	I _r	V _r =5V			50	μA
Viewing Angle	2 1/2	V _f =12V		35		deg

Notes: 1. The datas tested by IS tester.

2. Customer's special requirements are also welcome.

Chromaticity Coordinates Specifications for Bin Grading:

COLOR RANKS(IF=20Ma.Ta=25)

BiN	RANK					BiN	RANK				
A1	X	0.27	0.28	0.291	0.281	B5	X	0.296	0.304	0.315	0.307
	Y	0.265	0.282	0.273	0.256		Y	0.307	0.319	0.311	0.298
A2	X	0.281	0.291	0.302	0.292	B6	X	0.307	0.315	0.326	0.318
	Y	0.256	0.273	0.265	0.248		Y	0.298	0.311	0.303	0.29
B1	X	0.28	0.288	0.299	0.291	B7	X	0.304	0.312	0.323	0.315
	Y	0.282	0.294	0.286	0.273		Y	0.319	0.331	0.323	0.311
B2	X	0.291	0.299	0.31	0.302	B8	X	0.315	0.323	0.334	0.326
	Y	0.273	0.286	0.277	0.265		Y	0.311	0.323	0.315	0.303
B3	X	0.288	0.296	0.307	0.299	C1	X	0.312	0.322	0.333	0.323
	Y	0.294	0.307	0.298	0.286		Y	0.331	0.348	0.34	0.323
B4	X	0.299	0.307	0.318	0.31	C2	X	0.323	0.333	0.344	0.334
	Y	0.286	0.298	0.29	0.277		Y	0.323	0.34	0.332	0.315

Notes:X.Y Tolereanceeach Bin limit is ± 0.01 .

Chromaticity Coordinates & Bin grading diabram:

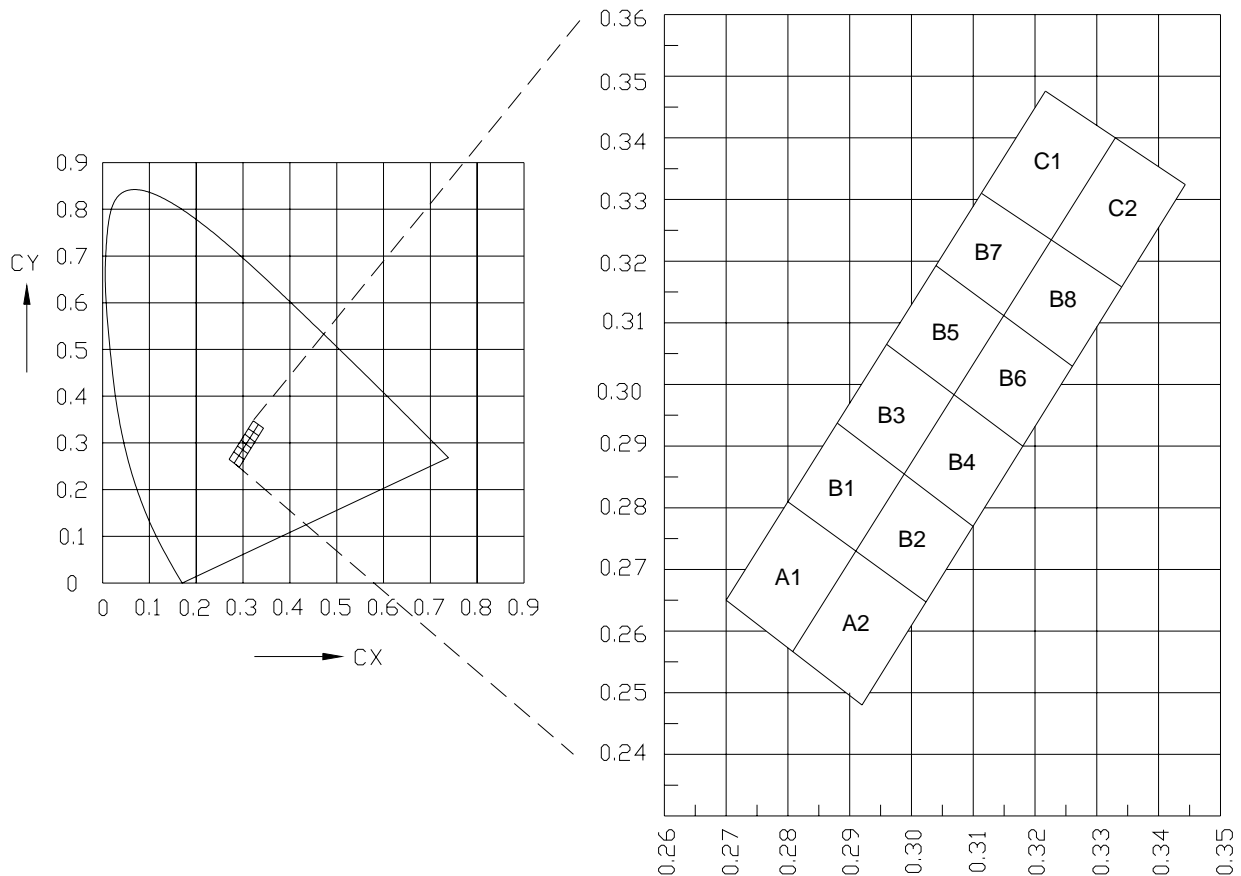

Typical Electrical / Optical Characteristics Curves :

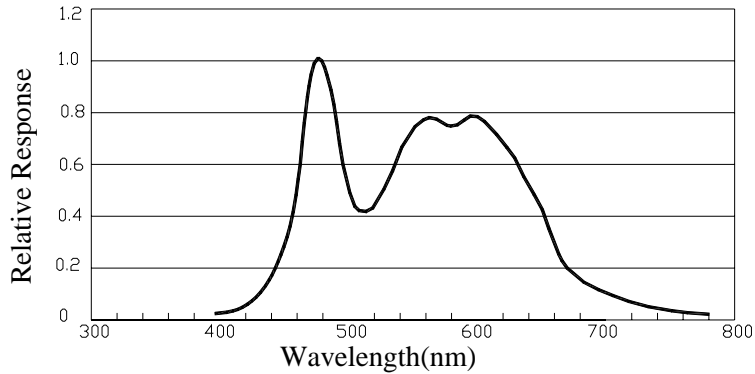

WHITE LED SPECTRUM VS. WAVELENGTH

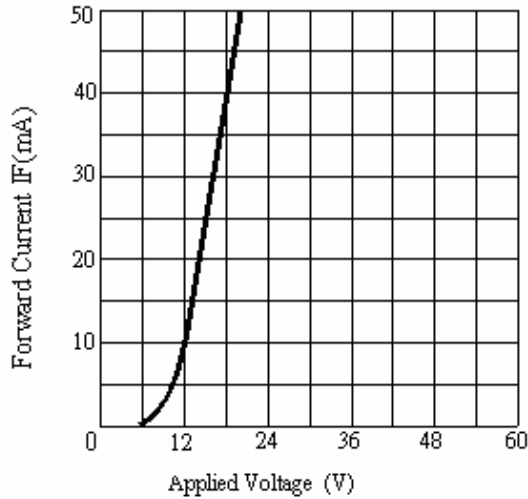

FORWARD CURRENT VS. APPLIED VOLTAGE

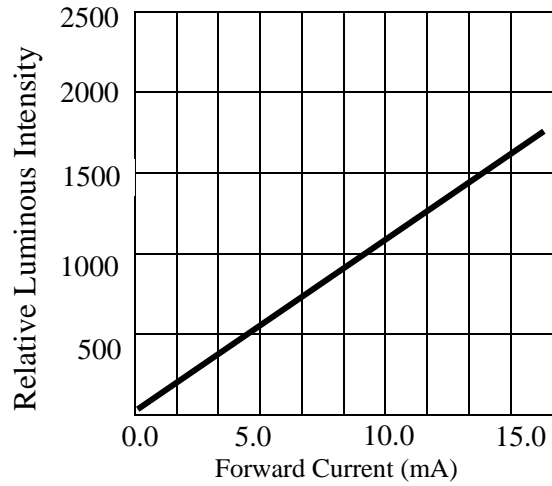

FORWARD CURRENT VS. LUMINOUS INTENSITY

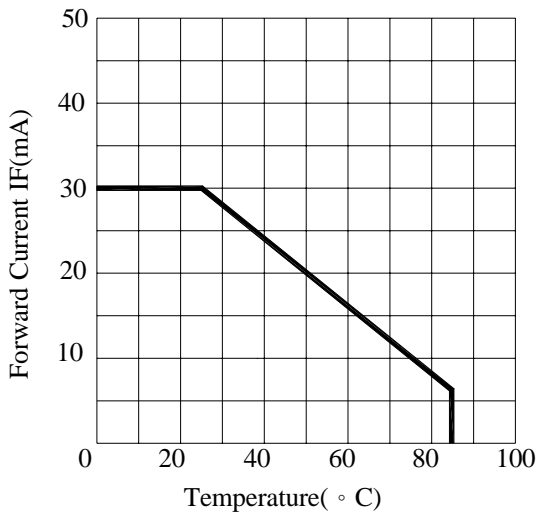

FORWARD CURRENT VS. AMBIENT TEMPERATURE

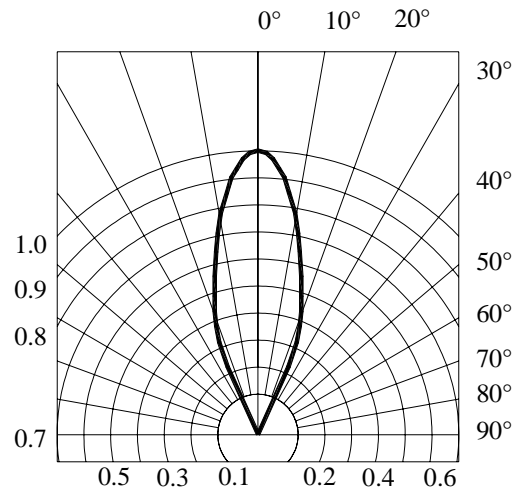

RADIATION DIAGRAM

Precautions:

TAKE NOTE OF THE FOLLOWING IN USE OF LED

1. Temperature in use

Since the light generated inside the LED needs to be emitted to outside efficiently, a resin with high light transparency is used; therefore, additives to improve the heat resistance or moisture resistance (silica gel, etc) which are used for semiconductor products such as transistors cannot be added to the resin.

Consequently, the heat resistant ability of the resin used for LED is usually low; therefore, please be careful on the following during use.

Avoid applying external force, stress, and excessive vibration to the resins and terminals at high temperature. The glass transition temperature of epoxy resin used for the LED is approximately 120-130 .

At a temperature exceeding this limit, the coefficient of linear expansion of the resin doubles or more compared to that at normal temperature and the resin is softened.

If external force or stress is applied at that time, it may cause a wire rupture.

2. Soldering

Please be careful on the following at soldering.

After soldering, avoid applying external force, stress, and excessive vibration until the products go to cooling process (normal temperature), <Same for products with terminal leads>

(1) Soldering measurements:

Distance between melted solder side to bottom of resin shall be 1.6mm or longer.

(2) Dip soldering :

Pre-heat: 90 max. (Backside of PCB), Within 60 seconds.

Solder bath: 260±5 (Solder temperature), Within 5 seconds.

(3) Hand soldering: 350 max. (Temperature of soldering iron tip), Within 3 seconds.

3. Insertion

Pitch of the LED leads and pitch of mounting holes need to be same.

4. Others

Since the heat resistant ability of the LED resin is low, SMD components are used on the same PCB, please mount the LED after adhesive baking process for SMD components. In case adhesive baking is done after LED lamp insertion due to a production process reason, make sure not to apply external force, stress, and excessive vibration to the LED and follow the conditions below.

Baking temperature: 120 max. Baking time: Within 60 seconds.

If soldering is done sequentially after the adhesive baking, please perform the soldering after cooling down the LED to normal temperature.

ENCASED TYPE

PLASTIC PACKAGE
QUANTITY: 200 PCS

LEDTECH ELECTRONICS CORP.	
PART NO :LTXXXX-XX	
Q'TY	: PCS
LOT NO	:XXXXXXXXXX
DATE	:
BIN CODE:	

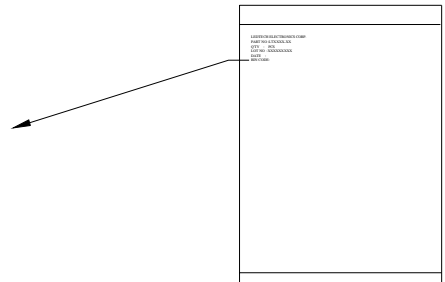

INNER BOX
QUANTITY: 40 PACKETS
TOTAL: 8,000 PCS

PART NO.	LXXXXX-XX-XX				
LOT NO.	XXXXXXXXXX				
BIN CODE	Xx X	Xx X	Xx X	Xx X	TOTAL
QUANTITY	PCS	PCS	PCS	PCS	PCS
DATE	XXXX . XX , XX				

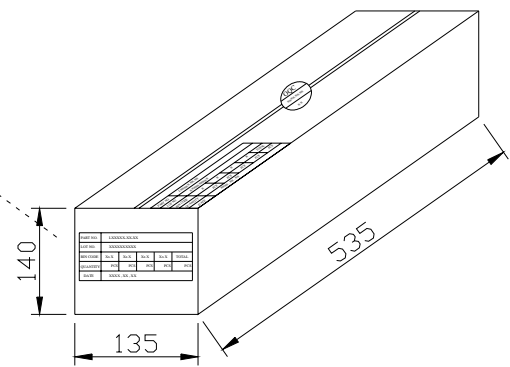

OUTER CARTON
QUANTITY: 4 BOX
TOTAL: 32,000 PCS

C/T NO. 箱號	XX
PART NO. 料號	LXXXXX-XX-XX
QUANTITY 數量	PCS
N.W. 淨重	KGS
G.W. 毛重	KGS
REMARK 備註	

