

Optocoupler, Phototransistor Output, Very High Isolation Voltage

Features

- Rated isolation voltage (RMS includes DC)
 $V_{IOWM} = 1000 V_{RMS}$ (1450 V peak)
- Rated recurring peak voltage (repetitive)
 $V_{IORM} = 1000 V_{RMS}$
- Thickness through insulation ≥ 3 mm
- Creepage current resistance according to VDE 0303/IEC 60112 Comparative Tracking Index:
CTI ≥ 200

Agency Approvals

- UL 1577 Recognized, File No. E76222
Coupling Systems:
CNY64 System Code H,
CNY65 System Code J,
CNY66 System Code K
- DIN EN 60747-5-2(VDE0884)
DIN EN 60747-5-5 pending
- VDE related features:
- Rated impulse voltage (transient overvoltage)
 $V_{IOTM} = 8$ kV peak
- Isolation test voltage (partial discharge test voltage) $V_{pd} = 2.8$ kV peak

Applications

Circuits for safe protective separation against electrical shock according to safety class II (reinforced isolation):

For appl. class I - IV at mains voltage ≤ 300 V

For appl. class I - IV at mains voltage ≤ 600 V

For appl. class I - III at mains voltage ≤ 1000 V according to DIN EN 60747-5-2(VDE0884)/ DIN EN 60747-5-5 pending, table 2, suitable for:

Switch-mode power supplies, line receiver, computer peripheral interface, microprocessor system interface.

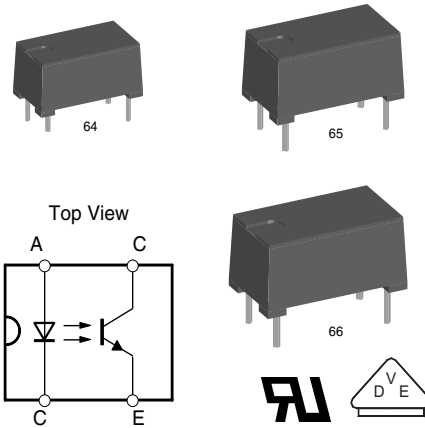

17187

Order Information

Part	Remarks
CNY64	CTR 50 - 300 %, High Isolation Distance, 4 PIN
CNY65	CTR 50 - 300 %, High Isolation Distance, 4 PIN
CNY66	CTR 50 - 300 %, High Isolation Distance, 4 PIN
CNY64A	CTR 63 - 125 %, High Isolation Distance, 4 PIN
CNY65A	CTR 63 - 125 %, High Isolation Distance, 4 PIN
CNY64B	CTR 100 - 200 %, High Isolation Distance, 4 PIN
CNY65B	CTR 100 - 200 %, High Isolation Distance, 4 PIN

Description

The CNY64/ CNY65/ CNY66 consist of a phototransistor optically coupled to a gallium arsenide infrared-emitting diode in a 4-pin plastic package.

The single components are mounted opposite one another, providing a distance between input and output for highest safety requirements of > 3 mm.

VDE Standards

These couplers perform safety functions according to the following equipment standards:

DIN EN 60747-5-2(VDE0884)/ DIN EN 60747-5-5 pending

Optocoupler for electrical safety requirements

IEC 60950/EN 60950

Vishay Semiconductors

Office machines (applied for reinforced isolation for mains voltage ≤ 400 VRMS)

VDE 0804

Telecommunication apparatus and data processing

IEC 60065

Safety for mains-operated electronic and related household apparatus

VDE 0700/IEC 60335

Household equipment

VDE 0160

Electronic equipment for electrical power installation

VDE 0750/IEC 60601

Medical equipment

Absolute Maximum Ratings

$T_{amb} = 25$ °C, unless otherwise specified

Stresses in excess of the absolute Maximum Ratings can cause permanent damage to the device. Functional operation of the device is not implied at these or any other conditions in excess of those given in the operational sections of this document. Exposure to absolute Maximum Rating for extended periods of the time can adversely affect reliability.

Input

Parameter	Test condition	Symbol	Value	Unit
Reverse voltage		V_R	5	V
Forward current		I_F	75	mA
Forward surge current	$t_p \leq 10$ μ s	I_{FSM}	1.5	A
Power dissipation		P_{diss}	120	mW
Junction temperature		T_j	100	°C

Output

Parameter	Test condition	Symbol	Value	Unit
Collector emitter voltage		V_{CEO}	32	V
Emitter collector voltage		V_{ECO}	7	V
Collector current		I_C	50	mA
Collector peak current	$t_p/T = 0.5$, $t_p \leq 10$ ms	I_{CM}	100	mA
Power dissipation		P_{diss}	130	mW
Junction temperature		T_j	100	°C

Coupler

Parameter	Test condition	Symbol	Value	Unit
AC isolation test voltage (RMS)	$t = 1$ min	V_{ISO}	8.2	kV
Total power dissipation		P_{tot}	250	mW
Ambient temperature range		T_{amb}	- 55 to + 85	°C
Storage temperature range		T_{stg}	- 55 to + 100	°C
Soldering temperature	2 mm from case, $t \leq 10$ s	T_{sld}	260	°C