

**NOTES:**

1. ROTATION TO BE ON VIEWING SHAFT EXT. END WITH RED LEAD POSITIVE.
2. 12 VOLT DC.
3. END PLAY LIMITED TO .003/.057.
4. LEADWIRE MATERIAL: 14 GA. TANNED COPPER STRANDED WIRE, 7/32 PVC INSULATION, RATED 105° C, TYPE UL-1015.
5. SEAL PLATE MATERIAL: 350 ALUMINUM, NO SUBSTITUTIONS (REF)
6. APPROVED SOURCE: MAMCO CORPORATION, FRANKSVILLE, WISCONSIN, VENDOR P/N: CP-12-132
7. DIMENSIONS ACROSS A CENTERLINE TO BE SPHERICAL ABOUT CENTERLINE WITH ONE HALF OF THE TOTAL TOLERANCE.
8. MAX. POROSITY ALLOWED: .02 DIA. ON WALLS OF SEAL POCKET.
9. MOTOR USES BEARING #17-077 SUPPLIED BY VENDOR USING STA-RITE TOOLING.
10. MAX. POROSITY ALLOWED: .040 DIA. IN CORNERS OF SEAL POCKET.
11. DENSITY OF POROSITY: THE DISTANCE BETWEEN ANY TWO HOLES SHALL NOT BE CLOSER THAN TWO TIMES THE DIA. OF THE SMALLER OF THE TWO HOLES. HOLES LESS THAN .005 ARE TO BE OMITTED.
12. SHAFT MATERIAL: 400 SERIES STAINLESS STEEL.

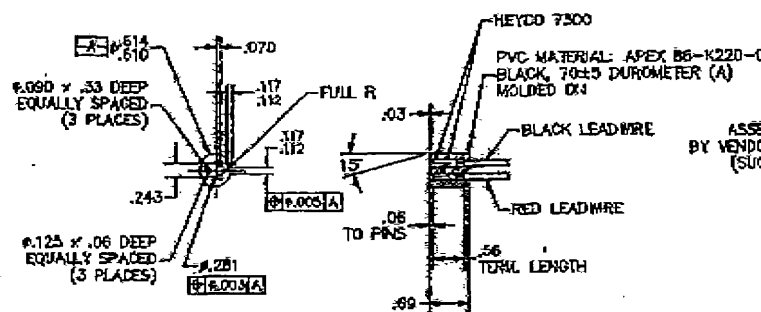

DETAIL A-A

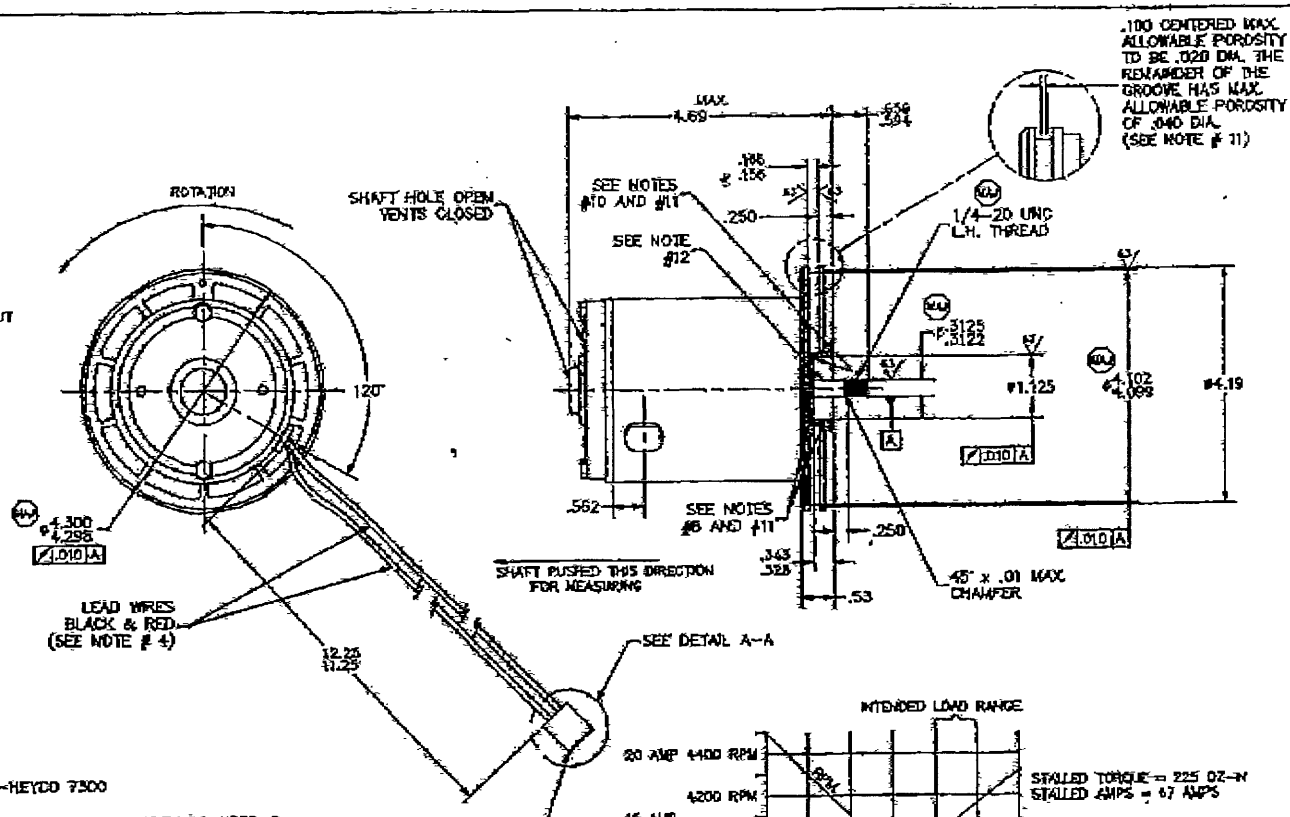
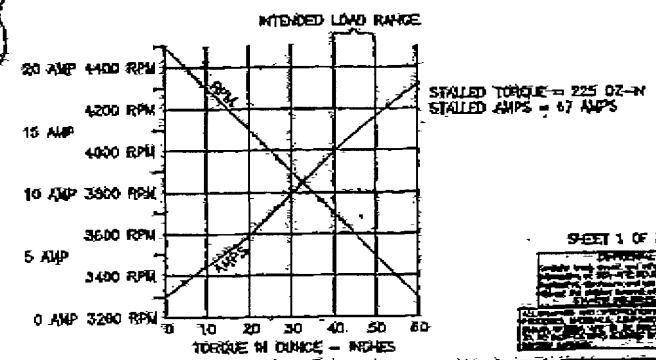

SHEET 1 OF 3

MANUFACTURED BY STA-RITE TOOLING CO. 517-088

REV	DATE	BY	CHKD	DESCRIPTION
1	2/15/07			MOTOR (12VDC)
2	2/15/07			517-088